



Serial No. : 2018-0053

DATE : 2018/01/22

Shanghai Winson Electronics Co.,LTD

ITEM :

CRYSTAL OSCILLATOR

TYPE : DSA535SG

NOMINAL FREQUENCY : 40.000MHz

SPEC No. : 1XTQ40000EGA

If there is a change in this specifications, the specification number may be changed.

RECEIPT	
DATE	
RECEIVED	(signature) (name)

General Manufacturer of Quartz Devices

DAISHINKU CORP.

1389 Shinzaike, Hiraoka-cho, Kakogawa, Hyogo
675-0194 Japan
Phone (81)79-425-3141 Fax (81)79-425-1134
http://www.kds.info/index_en.htm

C.ENG. *T. Takase*

ENG. *E. Kameda*

1. Device Name VC-TCXO
 2. Model Name DSA535SG
 3. Nominal Frequency 40.000 MHz
 4. Weight 0.08g max.

5. Absolute Maximum Value

	Item	Symbol	Rating	unit
1	Supply Voltage	V _{CC}	-0.3 ~ +6.0	V
2	Storage Temperature Range	T _{STG}	-40 ~ +85	°C

6. Recommended Operating Conditions

	Item	Symbol	min.	typ.	max.	unit
1	Supply Voltage	V _{CC}	+3.135	+3.3	+3.465	V
2	Frequency Control Voltage Range	V _{CONT}	+0.5	+1.5	+2.5	V
3	Output Enable					
	1. "L" level	V _{IL}	-	-	V _{CC} ×0.3	V
	2. "H" level	V _{IH}	V _{CC} ×0.7	-	-	V
4	Operable Temperature Range	T _{OPR}	-40	-	+85	°C
5	Load impedance (resistance part)	L _{CMOS}	-	15	-	pF

TITLE
DSA535SG TYPE SPECIFICATION

Remark

Date
2018/01/22

Spec. No.
1XTQ40000EGA

Rev.
-

Page
1/14

7. Electrical Characteristics

(T_A = -40 ~ +85 °C, L_{CMOS} = 15pF, V_{CC} = +3.3V, V_{CONT} = +1.5V unless otherwise noted)

	Item	Conditions	Limits			unit	Notes
			min.	typ.	max.		
1	Current consumption		-	-	+5.0	mA	
2	Output						1
	1. Rise Time	V _{CC} ×0.1 ~ V _{CC} ×0.9	-	-	7	ns	
	2. Fall Time	V _{CC} ×0.9 ~ V _{CC} ×0.1	-	-	7	ns	
	3. Low Level		-	-	V _{CC} ×0.1	V	
	4. High Level		V _{CC} ×0.9	-	-	V	
	5. Symmetry	V _{CC} ×0.5 Level	40/60	50	60/40	%	
3	Frequency Stability						
	1. Tolerance	After 2 times reflow (T _A = +25 °C)	-	-	±1.50	ppm	2,3
	2. vs Temperature	T _A = -40 ~ +85 °C	-	-	±0.28	ppm	4
	3. vs Supply Voltage	V _{CC} = +3.3V ±5%	-	-	±0.20	ppm	
	4. vs Load Variation	L _{CMOS} = 15pF ±5%	-	-	±0.20	ppm	
	5. vs Aging	T _A = Room ambient	-	-	±1.00	ppm/year	
4	Start Up Time	@90% of Final V _{OUT} level	-	-	2.0	ms	
		Within ±0.1ppm of final frequency	-	-	3.0	ms	
5	Frequency Control						
	1. Control Range	V _{CONT} = +1.5V ± 1.0V	±5.0	-	-	ppm	5
	2. Input Resistance		100	-	-	kΩ	
6	SSB Phase Noise	Relative to F0 Level Offset 100Hz	-	-	-103	dBc/Hz	
		Relative to F0 Level Offset 1kHz	-	-	-128	dBc/Hz	
		Relative to F0 Level Offset 10kHz	-	-	-145	dBc/Hz	

Notes

- CMOS Output
- Ref. to Nominal Frequency.
- Please leave after Reflow in 2H or more at room ambient.
- Ref. to Frequency (T_A = +25 °C)
- Positive slope (Frequency becomes high in proportion to frequency control voltage.)

TITLE
DSA535SG TYPE SPECIFICATION

Remark

Date
2018/01/22

Spec. No.
1XTQ40000EGA

Rev.
-

Page
2/14

8. Outline, Pin Connections

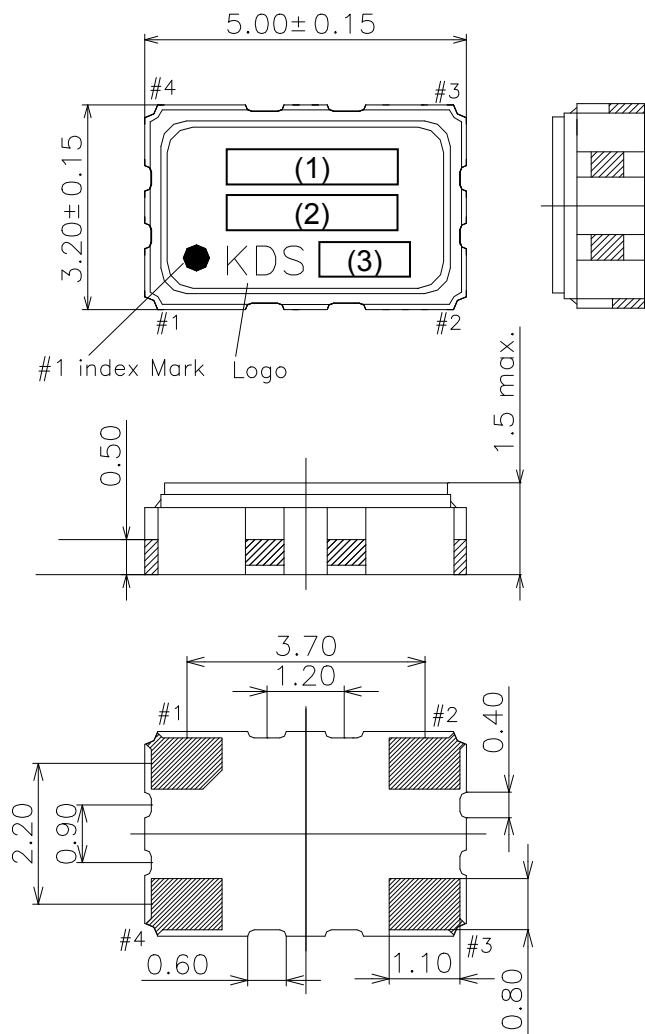

(Bottom View)

Pin Connections

Pin No.	Connection
#1	V _{CONT}
#2	GND
#3	OUTPUT
#4	V _{CC}

Marking

- (1) Frequency 40000 (kHz, 5digits)
- (2) Model code "A535SG"
- (3) Date code Year (1digit) + Week (2digits)
e.g. 2018/1/1 → 801

unit:[mm]

Dimensional Tolerance: +/-0.15

(Unless otherwise noted)

9. Measurement Circuit

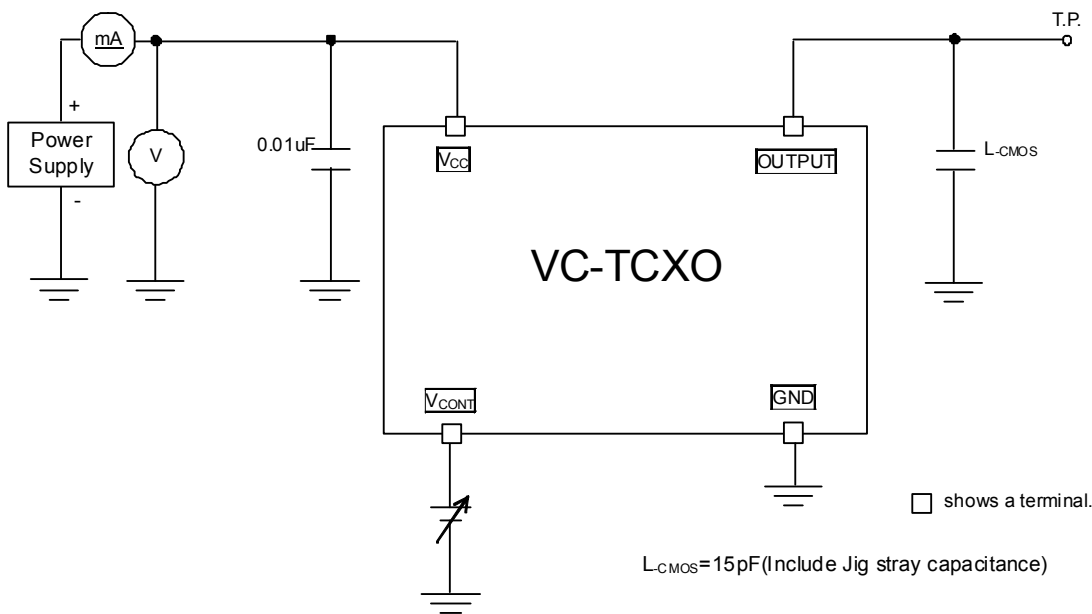

TITLE DSA535SG TYPE SPECIFICATION		Remark	
Date 2018/01/22	Spec. No. 1XTQ40000EGA	Rev. -	Page 3/14

10. Mechanical Characteristics

All test is performed after 3times reflow (Clause.13) except 10.10 (Resistance to soldering heat)

Item	Description	Requirements
1	Drop Natural drop (On concrete) Mounting on the set or test fixture.(Total weight 100g) Height : 150cm Direction : X,Y,Z, 6directions Test cycle : 3cycles Reference specification : EIAJ-ED-4702A Method5	df/f=<±1.0ppm
2	Vibration Sweep range : 10~500Hz Sweep speed : 11min/cycle Amplitude : 1.5mm (10~55Hz) Acceleration : 200m/s ² (55~500Hz) Direction : X,Y,Z, 3directions Test cycle : 10cycles Reference specification : IEC 60068-2-6	df/f=<±0.5ppm
3	Shock Acceleration : 1000m/s ² Direction : X,Y,Z, 6directions Duration : 6ms Test cycle : 3cycles/each directions Reference specification : IEC 60068-2-27	df/f=<±0.5ppm
4	PCB bend strength PWB : t=1.6mm Pressure speed : 1.0mm/s Bend width : 1→2→3mm Duration : 10±1s Reference specification : IEC 60068-2-21 Ue1	df/f=<±0.5ppm No visible damage. No leak damage.
5	Adherence nature PWB : t=1.6mm Direction : X,Y, 2directions Pressure : 10N Duration : 10±1s Reference specification : IEC 60068-2-21 Ue3	df/f=<±0.5ppm No visible damage. No leak damage.
6	Package strength Pressure : 10N Duration : 10±1s Reference specification : IEC 60068-2-77	df/f=<±0.5ppm No mechanical damage. No leak damage.
7	Gross leak It is immersed for 3min into +125±5°C Chlorofluorocarbon (CFCs) liquid. Reference specification : IEC 60068-2-17	No continuous air bubbles.
8	Fine leak It shall be measured by the helium leak detector after pressurization for 60min by the pressure of (3.92±0.49) x10 ⁵ Pa in a helium gas atmosphere. Reference specification : IEC 60068-2-17	Less than 1.0x10 ⁻⁹ Pa m ³ /s.
9	Solderability Solder bath temperature : +245±5°C Duration : 3±0.3s Reference specification : IEC 60068-2-58	A new uniform coating of solder shall cover a minimum of 95% of the surface being immersed.
10	Resistance to soldering heat 1) Solder iron method Bit size : B(φ3) Bit temperature : +350±10°C Duration : 3+1/-0s /each terminal It shall be measured after 2h at room temperature, humidity. Reference specification : IEC 60068-2-20	df/f=<±0.5ppm dV _{OUT} =<±0.2V _{P-P} No visible damage.
	2) Reflow In refer to temperature profile shown in clause13. Test cycle : 3cycles It shall be measured after 2h at room temperature, humidity. Reference specification : IEC 60068-2-58	df/f=<±1.0ppm dV _{OUT} =<±0.2V _{P-P} No visible damage.

TITLE DSA535SG TYPE SPECIFICATION		Remark		
Date 2018/01/22	Spec. No. 1XTQ40000EGA	Rev. -	Page 4/14	

11. Environmental Characteristics

All test is performed after 3times reflow (Clause13)

Item	Description	Requirements
1	Low temperature storage Temperature : $-40\pm 3^{\circ}\text{C}$ Duration : 1000h It shall be measured after 2h at room temperature, humidity. Reference specification : IEC 60068-2-1 Ab	$df/f = < \pm 1.0\text{ppm}$ $dV_{\text{OUT}} = < \pm 0.2V_{\text{P-P}}$ The electrical characteristics are satisfied.
2	High temperature storage Temperature : $+85\pm 2^{\circ}\text{C}$ Duration : 1000h It shall be measured after 2h at room temperature, humidity. Reference specification : IEC 60068-2-2 Bb	$df/f = < \pm 1.0\text{ppm}$ $dV_{\text{OUT}} = < \pm 0.2V_{\text{P-P}}$ The electrical characteristics are satisfied.
3	Humidity Temperature : $+85\pm 2^{\circ}\text{C}$ R.H. $85\pm 5\%$ Duration : 1000h It shall be measured after 2h at room temperature, humidity. Reference specification : IEC 60068-2-78	$df/f = < \pm 1.0\text{ppm}$ $dV_{\text{OUT}} = < \pm 0.2V_{\text{P-P}}$ The electrical characteristics are satisfied.
4	HTB Temperature : $+85\pm 2^{\circ}\text{C}$ Duration : 1000h BIAS : Max value of supply voltage It shall be measured after 2h at room temperature, humidity. Reference specification : IEC 60068-2-2 Bb	$df/f = < \pm 1.0\text{ppm}$ $dV_{\text{OUT}} = < \pm 0.2V_{\text{P-P}}$ The electrical characteristics are satisfied.
5	THB Temperature : $+40\pm 2^{\circ}\text{C}$ R.H. $90\sim 95\%$ Duration : 1000h BIAS : Max value of supply voltage It shall be measured after 2h at room temperature, humidity. Reference specification : IEC 60068-2-78	$df/f = < \pm 1.0\text{ppm}$ $dV_{\text{OUT}} = < \pm 0.2V_{\text{P-P}}$ The electrical characteristics are satisfied.
6	Thermal shock Thermal shock : $-40\pm 3^{\circ}\text{C} : 0.5\text{h} \Leftrightarrow +85\pm 2^{\circ}\text{C} : 0.5\text{h}$ Test cycle : 200cycles Shift time : 2~3min It shall be measured after 2h at room temperature, humidity. Reference specification : IEC 60068-2-14	$df/f = < \pm 1.0\text{ppm}$ $dV_{\text{OUT}} = < \pm 0.2V_{\text{P-P}}$ The electrical characteristics are satisfied.
7	ESD Model : Machine Model (MM) $V = \pm 200\text{V}$ (C=200pF, R=0 Ω) Number of times : 3times Each terminal except common terminal. (Connect to test terminal) Reference specification : EIA/JESD22-A115	$df/f = < \pm 1.0\text{ppm}$ $dV_{\text{OUT}} = < \pm 0.2V_{\text{P-P}}$ The electrical characteristics are satisfied.
	Model : Human Body Model (HBM) $V = \pm 1500\text{V}$ (C=100pF, R=1500 Ω) Number of times : 3times Each terminal except common terminal. (Connect to test terminal) Reference specification : EIA/JESD22-A114	$df/f = < \pm 1.0\text{ppm}$ $dV_{\text{OUT}} = < \pm 0.2V_{\text{P-P}}$ The electrical characteristics are satisfied.

TITLE DSA535SG TYPE SPECIFICATION	Remark		
Date 2018/01/22	Spec. No. 1XTQ40000EGA	Rev. -	Page 5/14

12. Flatness of Terminal

When the component is placed on the flat surface, the gap from the connecting terminal shall not exceed 0.05 mm.

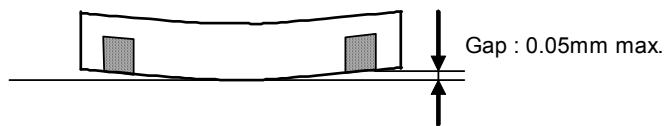

13. Reflow Profile

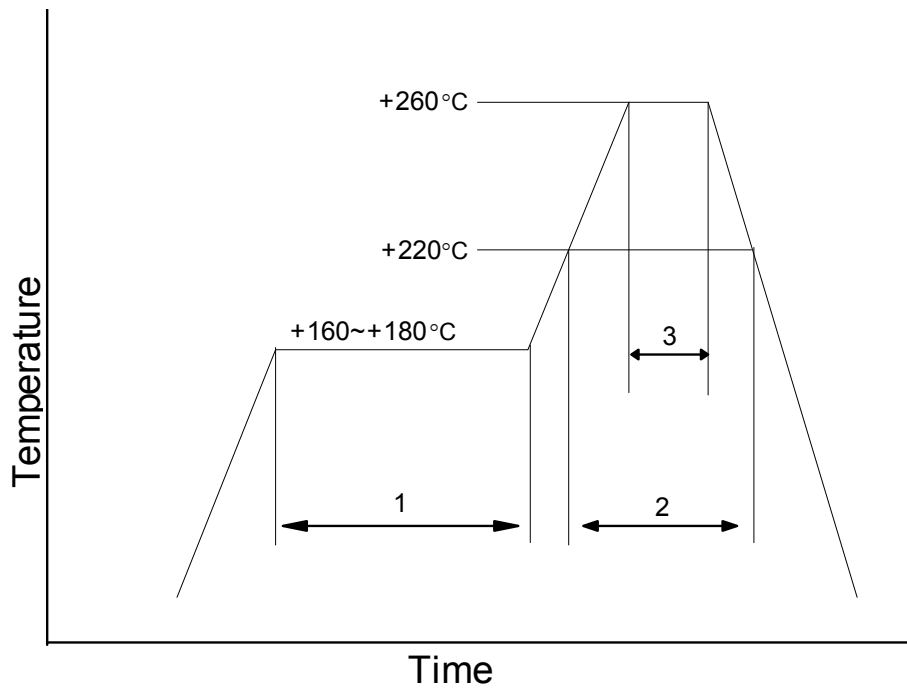

1	Preheat	+160~+180°C	120s
2	Primary Heat	+220°C	60s
3	Peak	+260°C	10s max.

TITLE DSA535SG TYPE SPECIFICATION		Remark		
Date 2018/01/22	Spec. No. 1XTQ40000EGA	Rev. -	Page 6/14	

14. Terminals / Land Pattern Layout / Metal Mask Hole

14.1 Terminals

A through hole is not located on the bottom (mounting side).

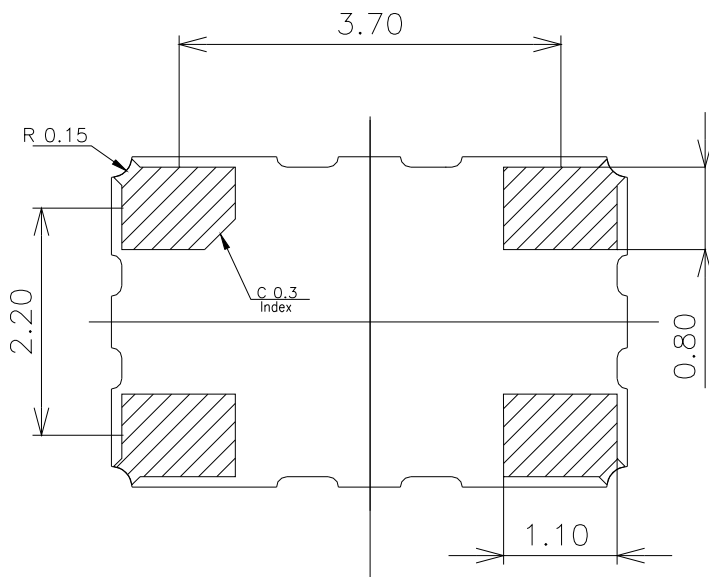

unit : mm
Dimensional Tolerance: ±0.15mm

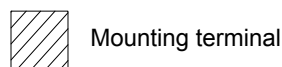

14.2 Land Pattern Layout / Metal Mask Hole

The following land pattern is reference design. The electrical characteristic shall be satisfied with mounting to this land. The land pattern can be changed in the limits to which a test land and a mounting land are not connected. And it does not any effect to the electrical characteristics. Mask thickness recommends 0.12mm.

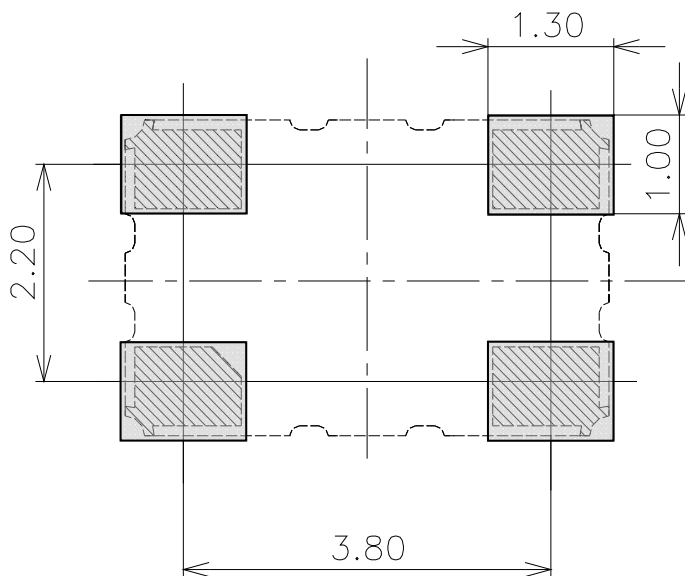

TOP VIEW
unit: mm
Dimensional Tolerance: ±0.15mm



TITLE DSA535SG TYPE SPECIFICATION		Remark	
Date 2018/01/22	Spec. No. 1XTQ40000EGA	Rev. -	Page 7/14

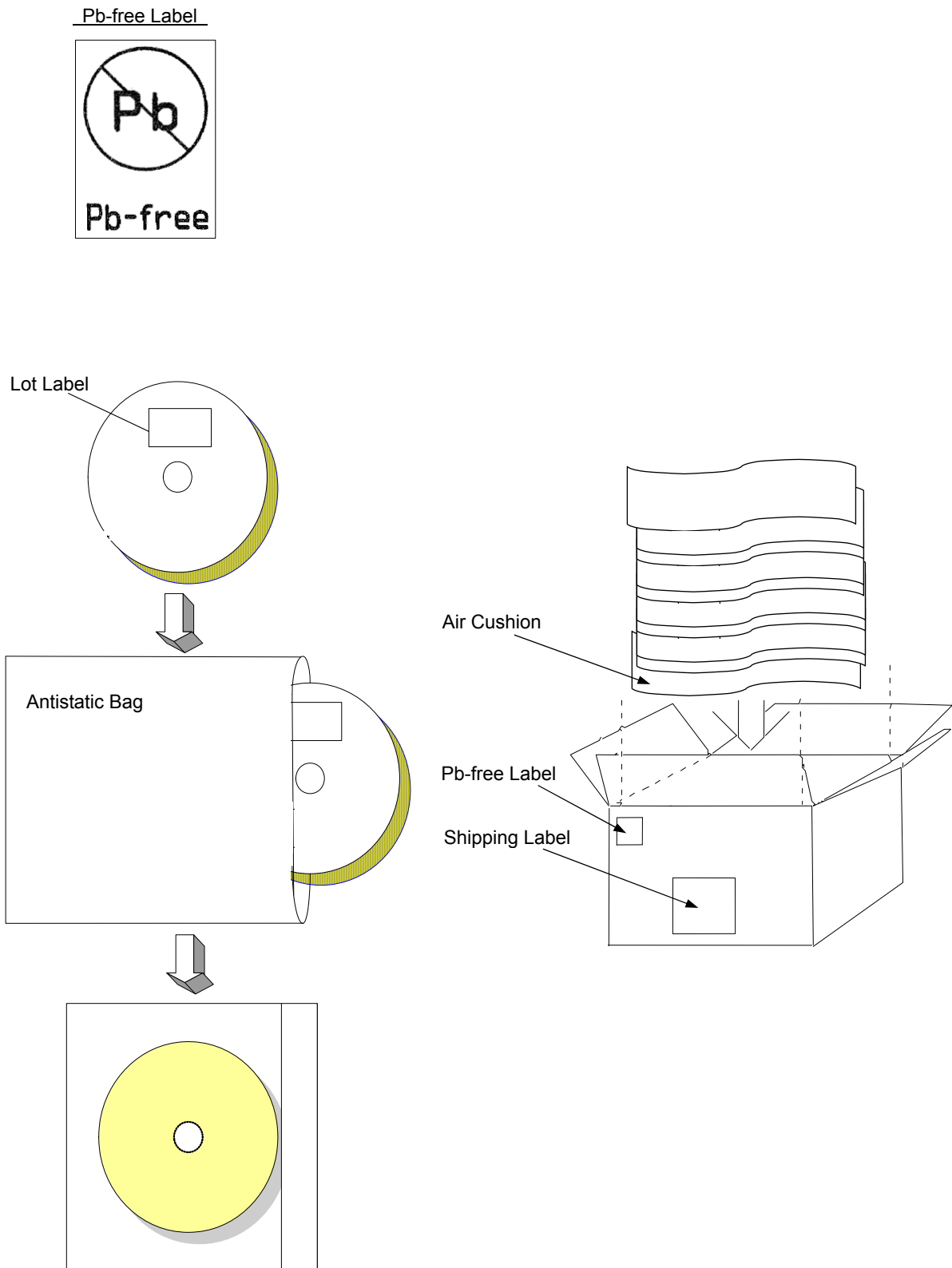

The product is packed up with the method which does not break in the handling by a shipping agent.

TITLE DSA535SG TYPE SPECIFICATION		Remark	
Date 2018/01/22	Spec. No. 1XTQ40000EGA	Rev. -	Page 9/14

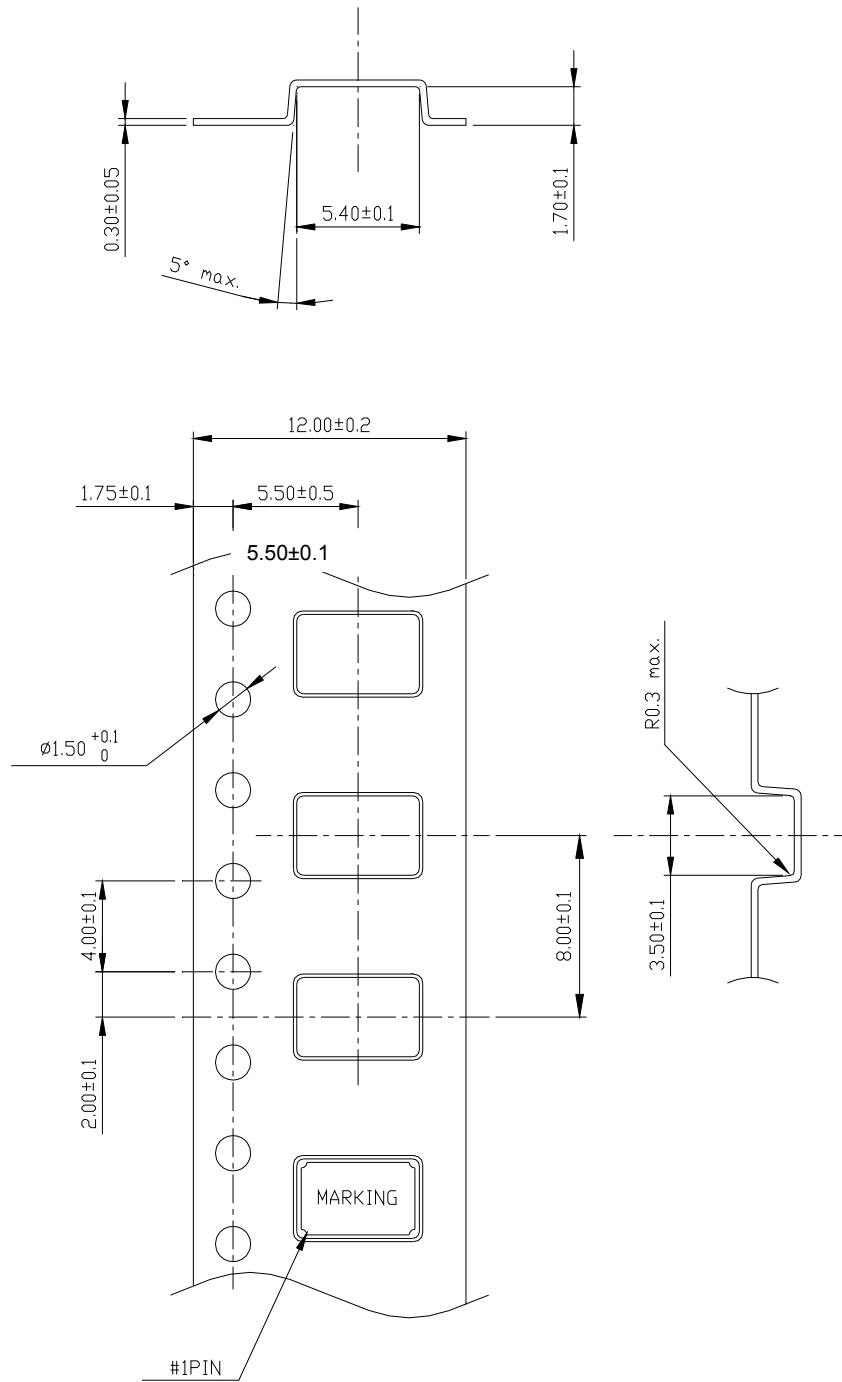

1. Clearance of an embossing tape, and a product unit: mm

Direction	Pocket size	TCXO size	Clearance
L	5.4±0.1	5.0±0.15	0.4±0.25
W	3.5±0.1	3.2±0.15	0.3±0.25
H	1.7±0.1	1.5 max.	0.2 min.

2. Quality : Polystyrene(Conductivity)

3. Tensile strength of an embossing tape : more than 14N

unit: mm

Fig.1. Emboss tape format and dimensions

TITLE DSA535SG TYPE SPECIFICATION		Remark	
Date 2018/01/22	Spec. No. 1XTQ40000EGA	Rev. -	Page 10/14

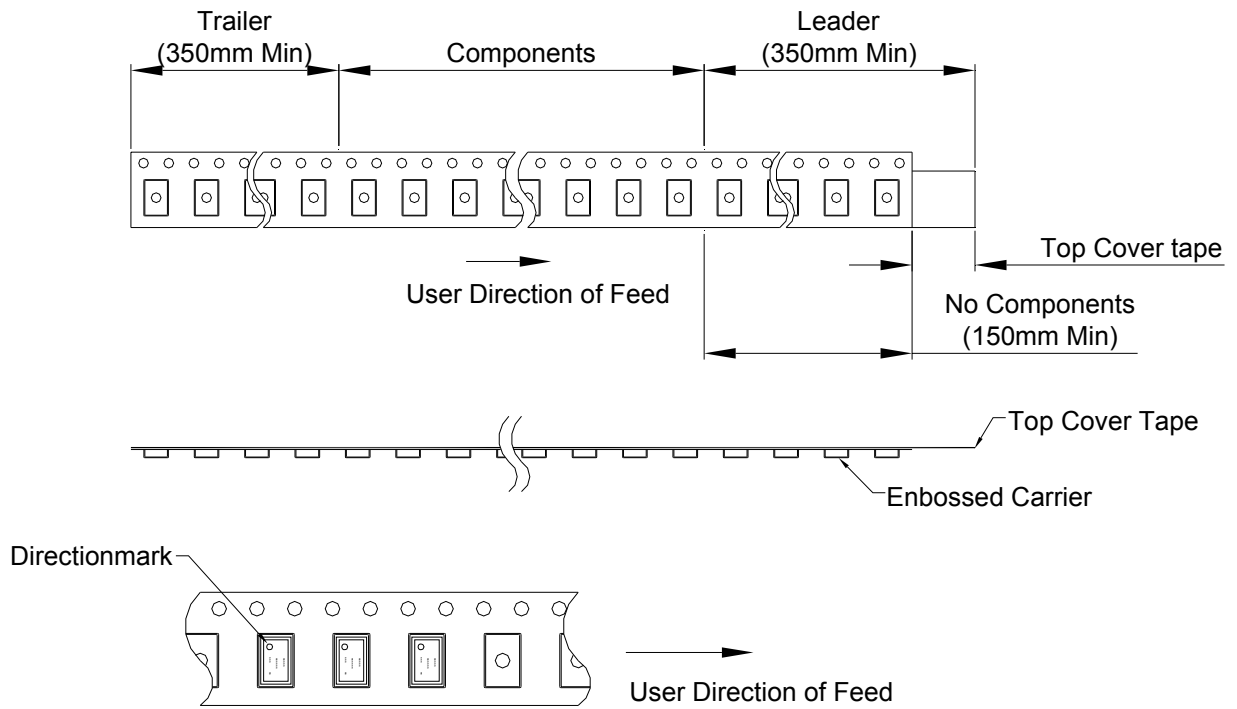

When a tape end is taken out to the front, sprocket holes becomes right hand side.

Peel strength

Pulling angle 165~180°, pulling speed at 300mm/min, strength should be 0.2~0.7N.

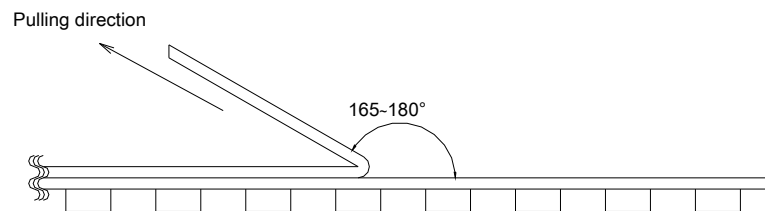

Fig.2. Taping specification

TITLE DSA535SG TYPE SPECIFICATION		Remark	
Date 2018/01/22	Spec. No. 1XTQ40000EGA	Rev. -	Page 11/14

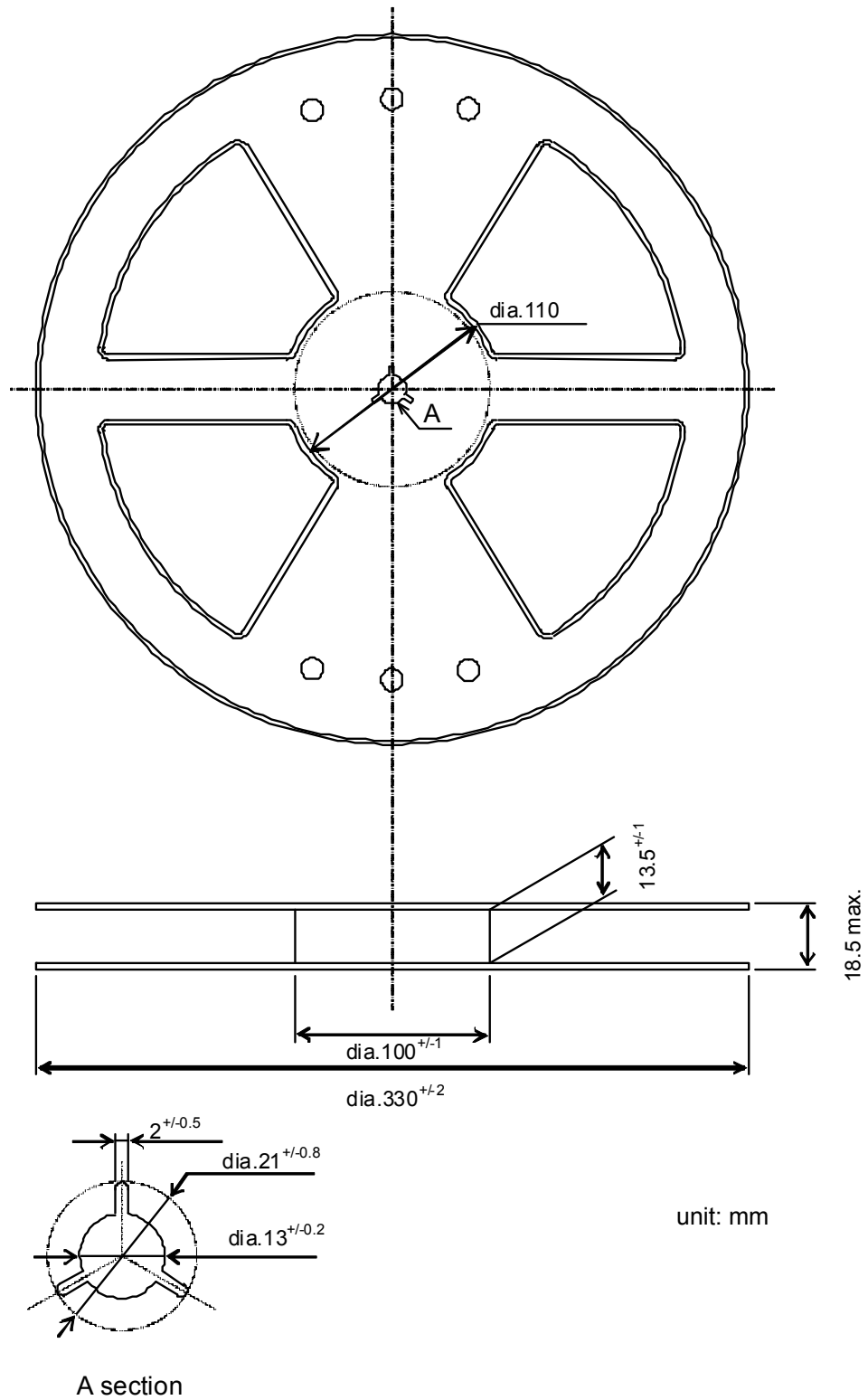

Fig.3. Reel specification

TITLE DSA535SG TYPE SPECIFICATION		Remark		
Date 2018/01/22	Spec. No. 1XTQ40000EGA	Rev. -	Page 12/14	

16. Notes on mounting and handling**16.1 Storage environment**

- (1) The temperature and humidity of a storage place, Please give +5~+40°C and 40~85% as a standard.
- (2) Please use this product within one year from the packing label date of issue.
- (3) Please avoid the place which generates corrosive gas, and the place with much dirt.
- (4) Please keep it in a place with little temperature change.

Dew condensation arises owing to a rapid temperature change and solderability becomes bad.

16.2 Be cautions to static electricity and high voltage.

16.3 This product has sufficient durability to fall and vibration. However, conditions may change to the fall after mounting to a PWB, and vibration. When you should drop on a floor the PWB which mounted the product or too much shock is added. Please use after a performance check.

16.4 Please check that the curvature of the substrate at the time of substrate cutting does not affect product. Moreover, especially when a product is near the position of a PWB guide pin, and the position of PWB break, be careful.

16.5 The part concerned does not correspond to washing.

16.6 Please repair at +260°C in 10s with hot air or +350°C in 5s with solder Iron.

17. Mandatory control**17.1 Ozone-depleting substance**

It regulates by the U.S. air purifying method (November, 1990 establishment). ODS of CLASS1 and CLASS2 is not contained or used.

17.2 PBDE, PBBs

PBDE, PBBs are not contained into all the material currently used for this product.

17.3 RoHS

Following material restricted by RoHS (2011/65/EU) is not included or used. Lead, mercury, cadmium, hexavalent , chromium ,PBB and PBDE.

17.4 Law Concerning Examination and Regulation of Manufacture, etc. of Chemical Substances

All the material currently used for this product is based on "Law Concerning Examination and Regulation of Manufacture, etc. of Chemical Substances". It is a registered material.

17.5 Lead

Leads, such as solder, are not used for this product. (Lead Free)

17.6 About the existence of silver and mercury use

The silver of very small quantity is contained in the conductive adhesives used for adhesion of Blank.

Moreover, mercury is used. It does not get down.

18. The country of origin / factory name / address

Country of origin: Japan

Factory name: DAISHINKU Corp. Tottori Production Div.

Address: 7-3-21 Wakabadai minami, Tottori 689-1112

TITLE DSA535SG TYPE SPECIFICATION		Remark		
Date 2018/01/22	Spec. No. 1XTQ40000EGA	Rev. -	Page 13/14	

