

RoHS Compliant
Directive 2011/65/EU

SPECIFICATION

Customer: CHENGDU NGV TECHNOLOGY EQUIPMENT CO., LTD

Item: <u>Crystal Unit</u>	Receipt
Type: <u>NX8045GE</u>	
Nominal Frequency: <u>4 MHz</u>	
Customer's Spec. No.:	
NDK Spec. No.: <u>EXS00A-CG04461</u>	

Charge:

Sales	Suzhou NDK Co., Ltd. Sales Dept LIU	Tel. (86)-5126-8252071	Approved	H.Kobayashi
Engineer	1 st Engineering Dept. Shariman Rahman	Tel. (81)-4-2900-6631	Checked	---
			Drawn	R.Shariman

Revision Record				
Rev.	Rev. Date	Items	Contents	Remarks
-----	5. Jul. 2013	Issue		

- 1.Customer specifications number :
- 2.NDK specification number : EXS00A-CG04461
- 3.Type : NX8045GE
- 4.Electrical characteristics
- 4.1 Nominal frequency : 4 MHz
- 4.2 Overtone order : Fundamental
- 4.3 Frequency tolerance : $\pm 50 \times 10^{-6}$ max. (+25 °C)
- 4.4 Frequency versus temperature characteristics : $\pm 100 \times 10^{-6}$ max. (-40~+125 °C)
The reference temperature shall be 25°C
- 4.5 Equivalent resistance : 150Ω max.
- 4.6 Maximum level of drive : 500μW max.
- 4.7 Insulation resistance : Terminal to terminal insulation resistance also terminal to cover insulation resistance must be 500MΩ (min) when DC100V ±15V is applied.
5. Measurement circuit
- 5.1 Frequency measurement
- *Measuring instrument : π-Network
- * Load capacitance(C_L) : 16pF
- *Level of drive : 50μW
- 5.2 Equivalent resistance measurement
- * Measuring instrument : π-Network
- * Load capacitance(C_L) : Series
- *Level of drive : 50μW
6. Other performances
- 6.1 Storage temperature range : -40~+150°C
- 6.2 Air-tightness : Less than 3×10^{-9} Pa m³/s (Helium leak detector)
7. Examination results document
Since a performance is guaranteed, an examination results document does not submit.
8. Application drawing
- 8.1 External dimension : EXD14B-00490
- 8.2 Taping and reel figure : EXK17B-00007
- 8.3 Holder marking : EXH11B-00099
- 8.4 Reliability assurance Item : EXS30B-00053
- 8.5 Recommendation reflow profile : EXS30B-00344

9. Notice

- 9.1 Order items are manufactured according to specification. As to conditions, which are not indicated in this specification and unpredictable such as applied condition and oscillation margin, please check them beforehand.
- 9.2 Crystal units will be damaged by ultrasonic welding process due to resonance of crystal wafer itself. NDK does not recommend using ultrasonic welding. If Ultra Sonic welding used, NDK strongly recommend verifying crystal unit damage by ultrasonic weld.
- 9.3 Unless we receive request for modification within 3 weeks from the issue date of this NDK specification sheet, we will supply products according to this specification. Also, if you'd like to modify specification of order, which has been placed with delivery request within 3 weeks from the issue data of this specification sheet, we would like to discuss with you separately.
- 9.4 In no event shall the company be liable for any product failure resulting from an inappropriate handling or operation of the product beyond the scope of its guarantee.
- 9.5 Where any change to the process condition is made due to the change(s) in the production line, inform personnel of the specifications.
- 9.6 Should this specification data give rise to any disputes relating to any intellectual property rights or any other rights of a third person, the company shall not indemnify anyone for any damage. Their disclosure must not be construed as the grant of a license to use any of the intellectual property rights owned by the company.
- 9.7 If you intend to use products listed on this specification for applications that may result in loss of life or assets (controls relating to safety, medical equipment, aeronautical equipment, space equipment, etc.), please do not fail to advise us of your intention beforehand.
- 9.8 In the company's production process whatever amount of ozone depleting substances (ODS) as specified in the Montreal protocol is not used.
- 9.9 Information contained in this specification must not be quoted, reproduced or used for other purposes including processing either in part or in full without obtaining prior approval from the company.
- 9.10 The appearance color and so on have a different case by purchasing it more than 2 suppliers of the component, but characteristic and reliability are guaranteed.

10. Prohibited items

Be sure to use the product under the following conditions. Otherwise, the characteristics deterioration or destruction of the product may result.

(1)Reflow soldering heat resistance

Peak temperature: 265°C, 10 sec

Heating: 230°C or higher, 40 sec

Preheating: 150°C to 180°C, 120 sec

Reflow passage times: twice

(2)Manual soldering heat resistance

Pressing a soldering iron of 400°C on the terminal electrode for four seconds (twice).

When using a soldering iron, press its tip on the part below the sealed part, avoiding the glass-sealed part (otherwise, the glass will melt and air-tightness may be lost).

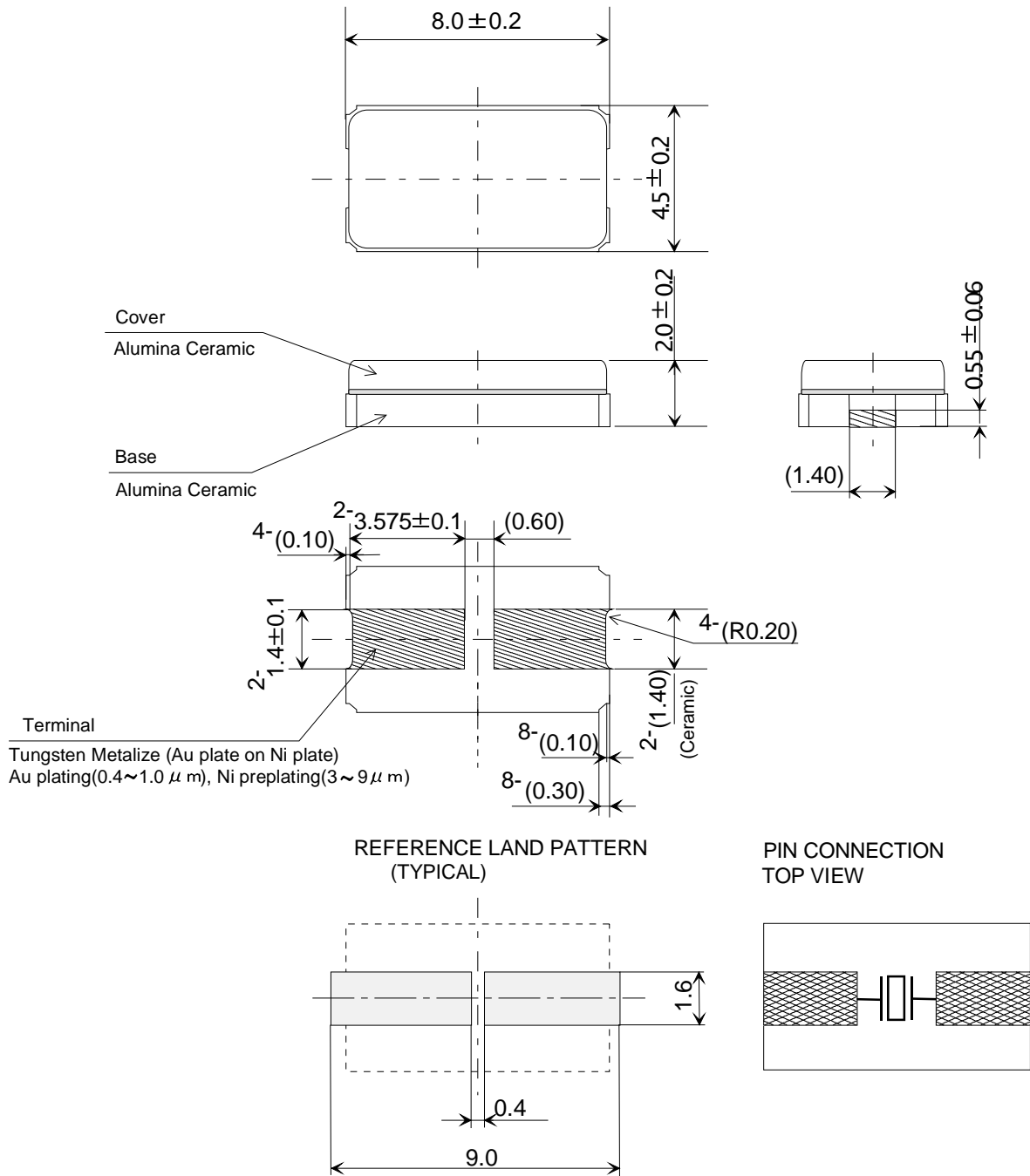

	Date of Revise	Charge	Approved	Reason	
A	18.Jan.2012	R.Shariman	K.Ueki	Add terminal tolerance	
	Date	Name	Third Angle Projection	Tolerance	Scale
Drawn	18.Jan.2011	R.Shariman	Dimension:mm		/
Designed	18.Jan.2011	R.Shariman	Title NX8045GE Dimension of External	Drawing No. EXD14B-00490	Rev.
Checked	18.Jan.2011	N.Yamamoto			A
Approved	18.Jan.2011	K.Ueki			

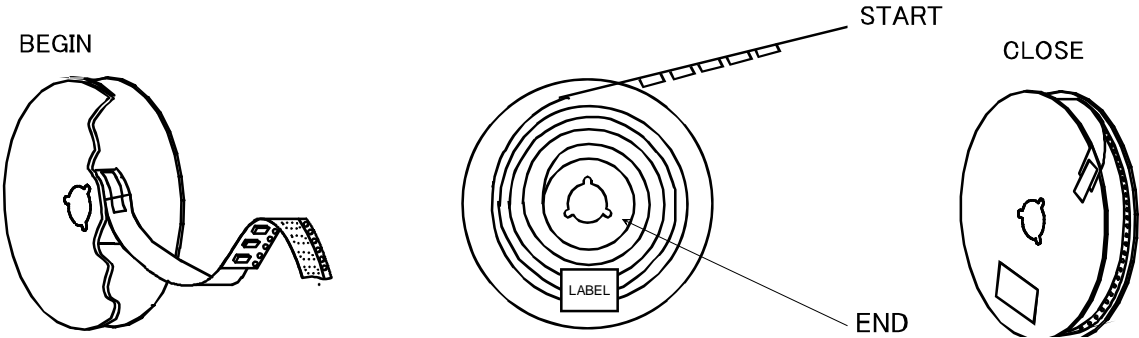
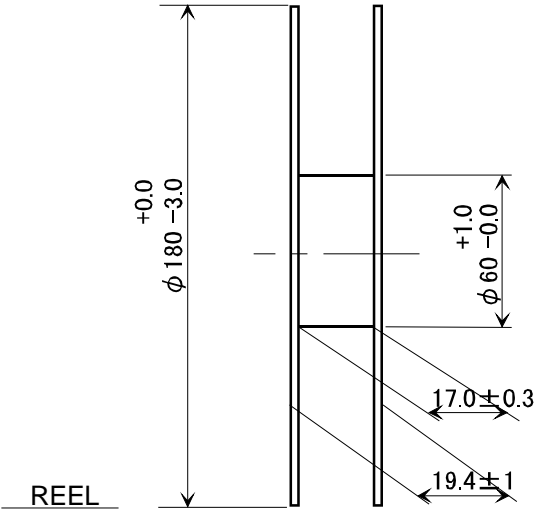
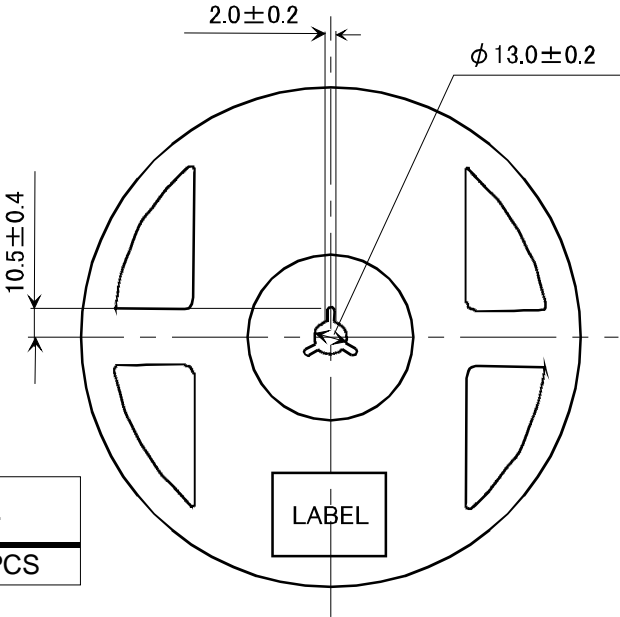
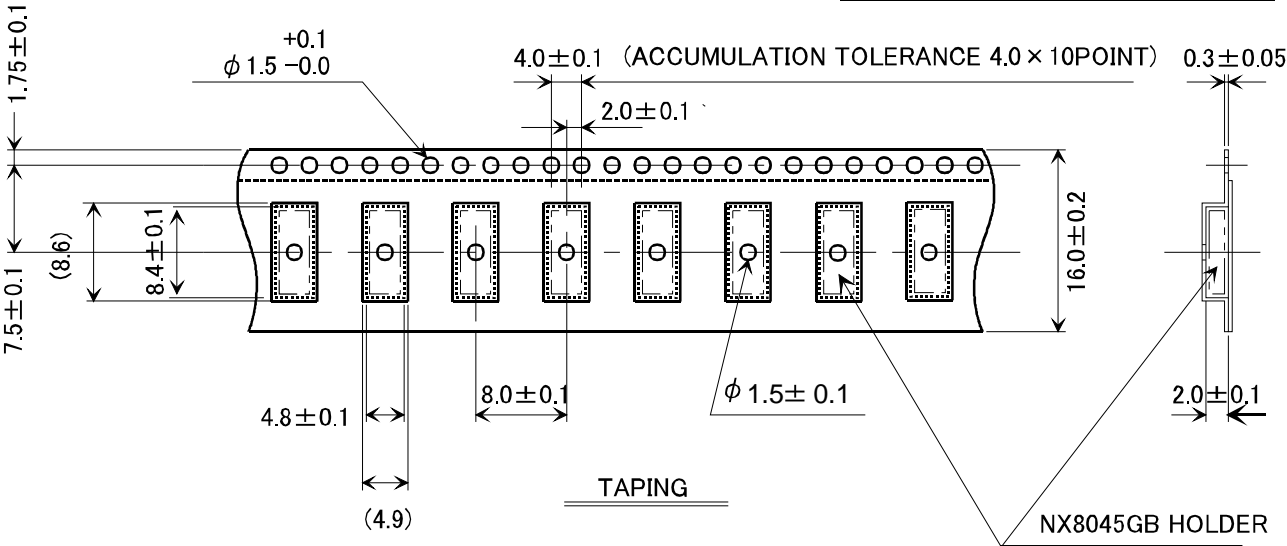

	Date of Revise	Charge	Approved	Reason	
C	12.Apr.2002	K.Nakashima	M.Miura	Correct diameter of hole of pocket	
	Date	Name	Third Angle Projection	Tolerance	Scale
Drawn	26.Mar.1999	K.Nakashima	Dimension:mm		/
Designed	26.Mar.1999	K.Nakashima	Title NX8045GB(TPR72-R/ TPR88-R)	Drawing No.	Rev.
Checked	-	-	TAPING AND REEL SPEC.	EXK17B-00007	C
Approved	26.Mar.1999	M.Okamoto			

NIHON DEMPA KOGYO CO., LTD.

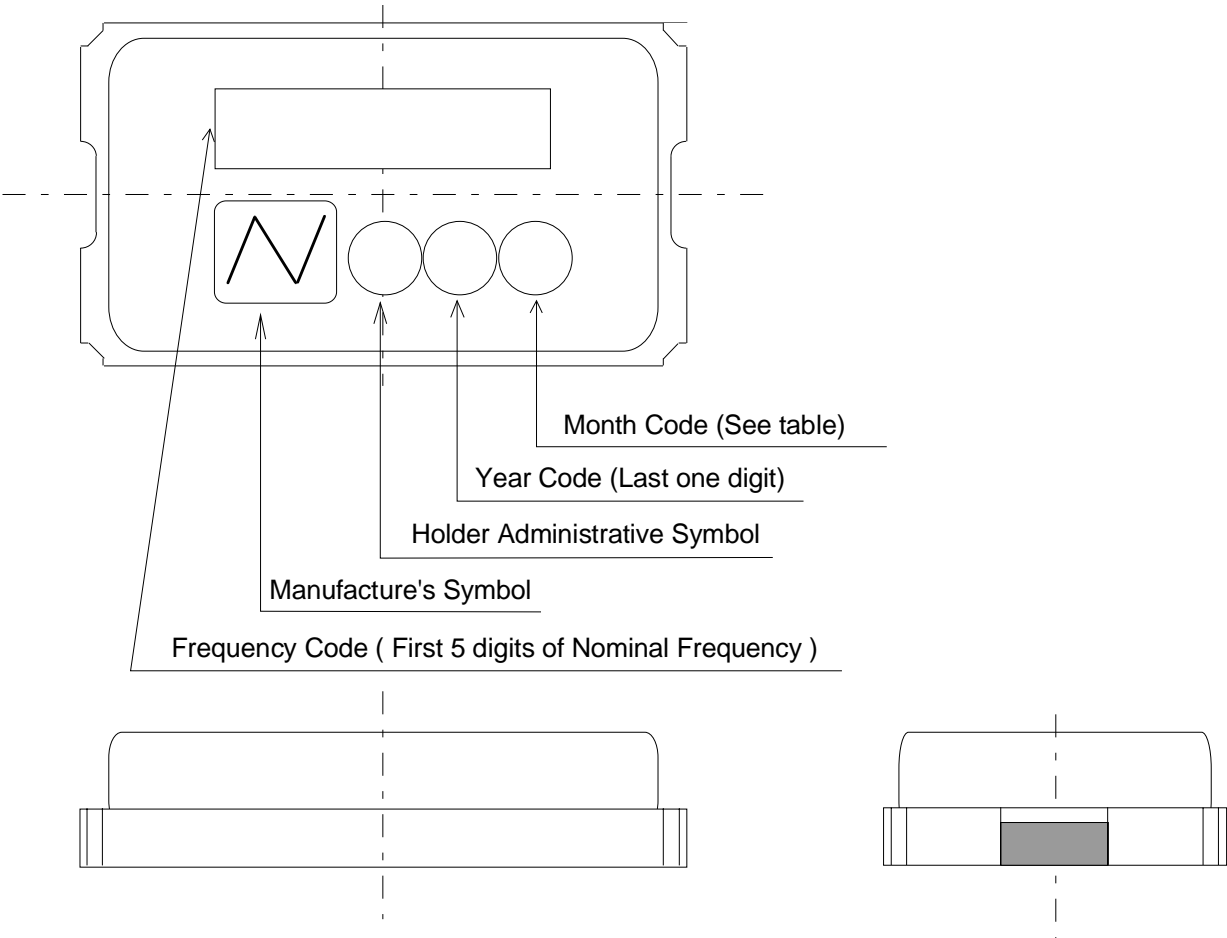

1. Marking contents

Example

Frequency Code	16.000
----------------	--------

2. Marking contents

Month	1	2	3	4	5	6	7	8	9	10	11	12
Month Code	1	2	3	4	5	6	7	8	9	X	Y	Z

3. Marking contents

Administrative symbol	S
-----------------------	---

* Marking digits are not include a decimal point and dot mark

	Date of Revise	Charge	Approved	Reason			
	Date	Name	Third Angle Projection	Tolerance		Scale	
Drawn	30.JULY.2001	N.Yamamoto	Dimension:mm			/	
Designed	30.JULY.2001	N.Yamamoto	Title NX8045GB Marking	Drawing No. EXH11B-00099		Rev.	
Checked	30.JULY.2001	M.Miura					
Approved	30.JULY.2001	T.Ishii					

NIHON DEMPA KOGYO CO., LTD.

Reliability assurance item

(page: 1/2)

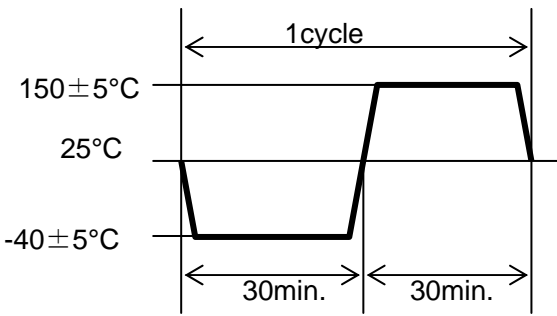
No.	Test item	Test methods	Spec. code
1	Drop	Devices are dropped from the height 75cm onto iron plate. Execution 3 times random drops.	A
2	Shock	Acceleration: 49000m/s^2 (5000G) Duration: 0.15msec Half-Sine pulse 1 Shocks in 6 mutually perpendicular planes, Total 6 shocks	A
3	Vibration	Frequency range: 10 to 2000 Hz Amplitude or Acceleration : 1.52 mm or 196m/s^2 (20G) Sweep time: 20 minutes Test time: 4 hours \times 3	A
4	Electrode adherent strength	See remark (1).	B
5	Solderability	Pre-heat temperature: 150°C Pre-heat Time: 60~120sec. Peak temperature: $240 \pm 5^\circ\text{C}$ 215°C Over time: 10~30sec.	C
6	Resistance to soldering heat	Pre-heat temperature: 150°C Pre-heat Time: 60~120sec. Peak temperature: $260 \pm 5^\circ\text{C}$ Test time: 10sec. max.	A,B
7	Resistance to cold	Leave at $-40^\circ\text{C} \pm 2^\circ\text{C}$ for 1000 hours.	A
8	Resistance to heat	Leave at $+150^\circ\text{C} \pm 2^\circ\text{C}$ for 1000 hours.	A
9	Humidity	Device are left in temperature at $+85^\circ\text{C}$ with relative humidity of 80~85% for 1000 hours.	A,D
10	Thermal shock	<p>Device are left into the following temperature cycle as shown in (Figure1) for 1000 consecutive cycle.</p>  <p>(Figure1)</p>	A,B

Reliability assurance item

(page: 2/2)

Spec. code	Specification
A	Frequency tolerance and series resistance should be cleared.
B	After testing unless cracking of materials view of eyes and unless break of seal.
C	The leads shall acquire a new solder coat cover at 90 % of immersed area.
D	Insulation resistance shall be greater than 500 MΩ

Remark (1) Electrode adherent strength.

1) Test method condition

Using the solder, soldering Iron or reflow soldering bath shall be used for soldering on test fixture (Glass fiber epoxy laminate : Thickness 1.6mm+/-0.2mm) shown below.

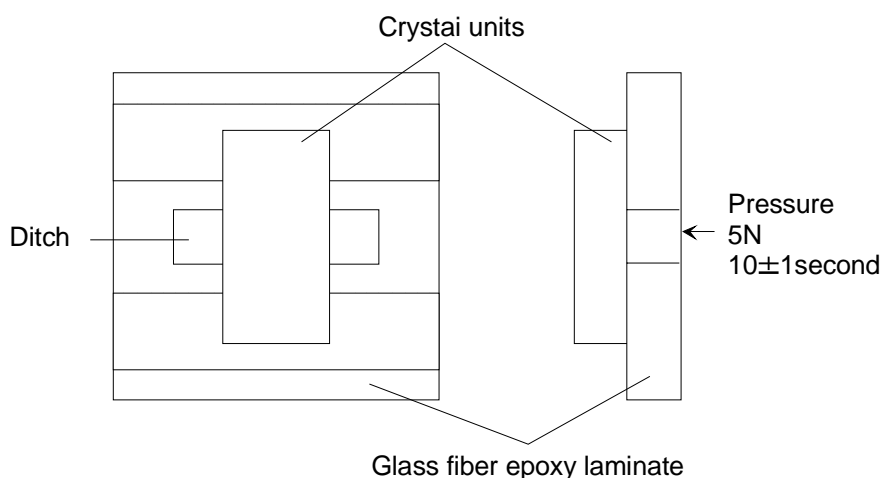
**2) Specified value**

No peel of electrode, no crack, no other abnormality

Recommendation reflow condition

1.IR reflow condition

