

SPECIFICATION FOR APPROVAL

CUSTOMER : _____

PRODUCT TYPE : SMD GLASS SEALING XTAL 5.0*3.2

NOMINAL FREQ. : 12.000000MHz

TXC P/N : 7A12000026

REVISION : A4

CUSTOMER P/N : _____

PM / SALES : _____

DATE : _____

CUSTOMER SIGNATURE & Date _____

- (1) TXC requires one copy returned with signature and title of authorized individual that signifies acceptance of the attached specifications.
- (2) Orders received and accepted by TXC after return of signed copy of specification will be produced per these specifications.
- (3) Any changes to these specifications must be agreed upon by both parties and new revision of the Product Specification Sheet will be issued.
- (4) Any issuance of purchase order prior to consigning back the Approval page of "Specification Sheets" from customers will be regarded as the agreement on the contents of these specifications.

Attachment: Product Specification Sheet

- 1
- 2
- 3
- 4
- 5

RoHS Compliant

Pb used in sealing glass material is exempt from EU directive



PRODUCT SPECIFICATION SHEET

PRODUCT TYPE : SMD GLASS SEALING XTAL 5.0*3.2

NOMINAL FREQ. : 12.000000MHz

TXC P/N : 7A12000026

REVISION : A4

PE/RD	QA	MFG
<i>Min-Chiang Chao</i>	<i>Jawson</i>	<i>Min-Chiang Chao</i>
<i>16-Feb-09</i>	<i>16-Feb-09</i>	<i>16-Feb-09</i>

NOTE:

- (1)Lead Free Products are "Directive 2002/95/EC of The European Parliament of 27 January 2003 on the restriction of the use of certain hazardous substances (RoHS) in electrical and electronic equipment" Compliant (Attachment: SGS Test Report).
- (2)Revision "Sx" is for engineering samples only. PE/RD's approval required.
- (3)Revision "Ax" is production ready. PE, QA and MFG's approval required.

RoHS Compliant

Pb used in sealing glass material is exempt from EU directive



<u>Rev</u>	<u>Revise page</u>	<u>Revise contents</u>	<u>Date</u>	<u>Ref.No.</u>	<u>Reviser</u>
A1	N/A	Initial released	6-Sep-04	N/A	Yachuan Miao
A2	3	Suggested Reflow Profile Change	2-Jun-05	ECN-05P050501	Yachuan Miao
A3	2	Rr Change (80Ω TO 40 Ω)	20-Apr-06	ECN-06P042002	Yachuan Miao
A4	N/A	Version Change "E"	16-Feb-09	ECN-08P112702	Xiaoyan Jiang

ELECTRICAL SPECIFICATIONS

Standard atmospheric conditions

Unless otherwise specified, the standard range of atmospheric conditions for making measurement and tests are as follow:

Ambient temperature : 25±5
 Relative humidity : 40%~70%

If there is any doubt about the results, measurement shall be made within the following limits:

Ambient temperature : 25±3
 Relative humidity : 40%~70%

Measure equipment

Electrical characteristics measured by S&A250B or equivalent.

Crystal cutting type

The crystal is using AT CUT (thickness shear mode).

Unit Weight:

0.062±0.001 g/pcs

	Parameters	SYM.	Electrical Spec.				Notes
			MIN	TYP	MAX	UNITS	
1	Nominal Frequency	FL	12.000000			MHz	-
2	Oscillation Mode	-	Fundamental			-	-
3	Load Capacitance	CL	16			pF	-
4	Frequency Tolerance	-	±30			ppm	at 25 ± 3
5	Frequency Stability	-	±30			ppm	Over Operating Temp. Range (Reference 25)
6	Operating Temperature	-	-10	~	70		-
7	Aging	-	±5			ppm	1st Year
8	Drive Level	DL	-	50	-	uW	-
9	Effective Resistance Rr	Rr	-	-	40	Ω	-
10	Shunt Capacitance C0	C0	-	-	5	pF	-
11	Insulation Resistance	-	500	-	-	MΩ	at DC 100V
12	Storage Temperature Range	-	-40	~	85		-

DIMENSIONS

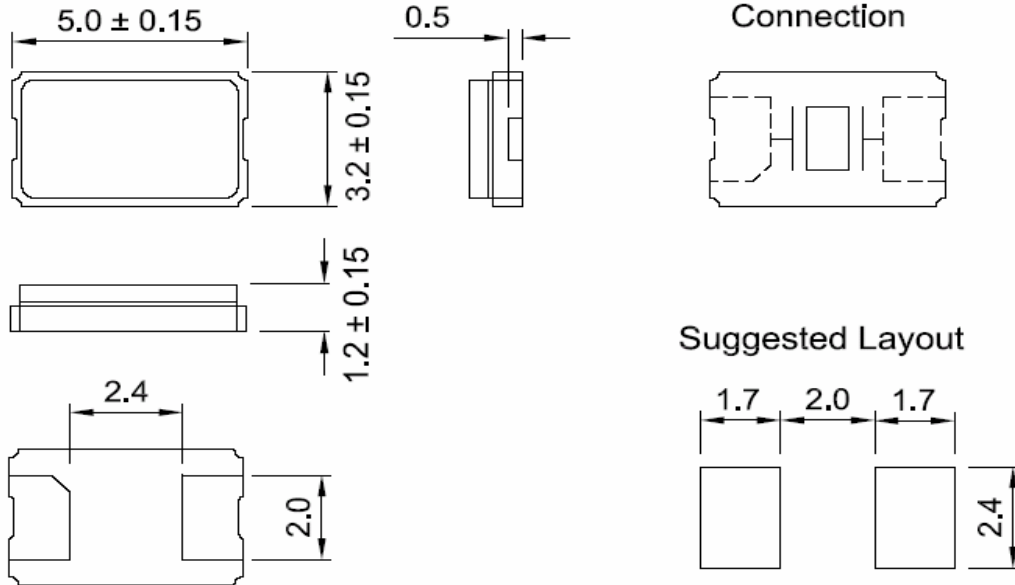

MARKING

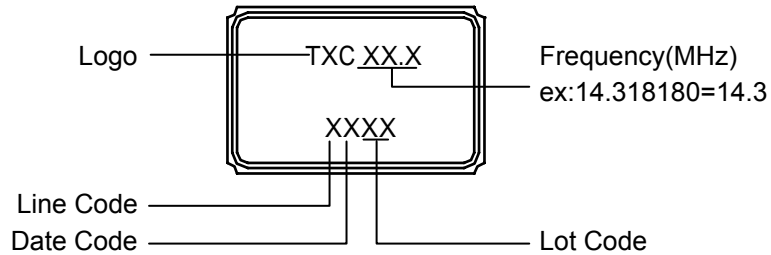

Production location: China

Date Code

YEAR \ MONTH					JAN	FEB	MAR	APR	MAY	JUN	JUL	AUG	SEP	OCT	NOV	DEC
					A	B	C	D	E	F	G	H	J	K	L	M
2001	2005	2009	2013	2017	N	P	Q	R	S	T	U	V	W	X	Y	Z
2002	2006	2010	2014	2018	a	b	c	d	e	f	g	h	j	k	l	m
2003	2007	2011	2015	2019	n	p	q	r	s	t	u	v	w	x	y	z
2004	2008	2012	2016	2020												

This date code will be cycled every four years

SUGGESTED REFLOW PROFILE

Total time : 200 sec. Max.

Solder melting point :220

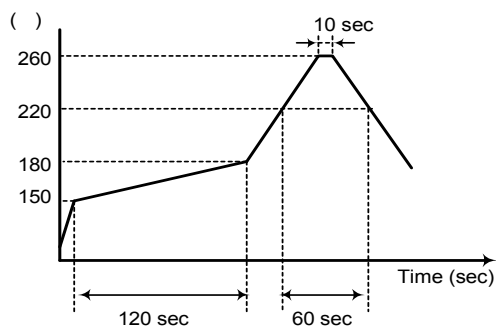

STRUCTURE ILLUSTRATION

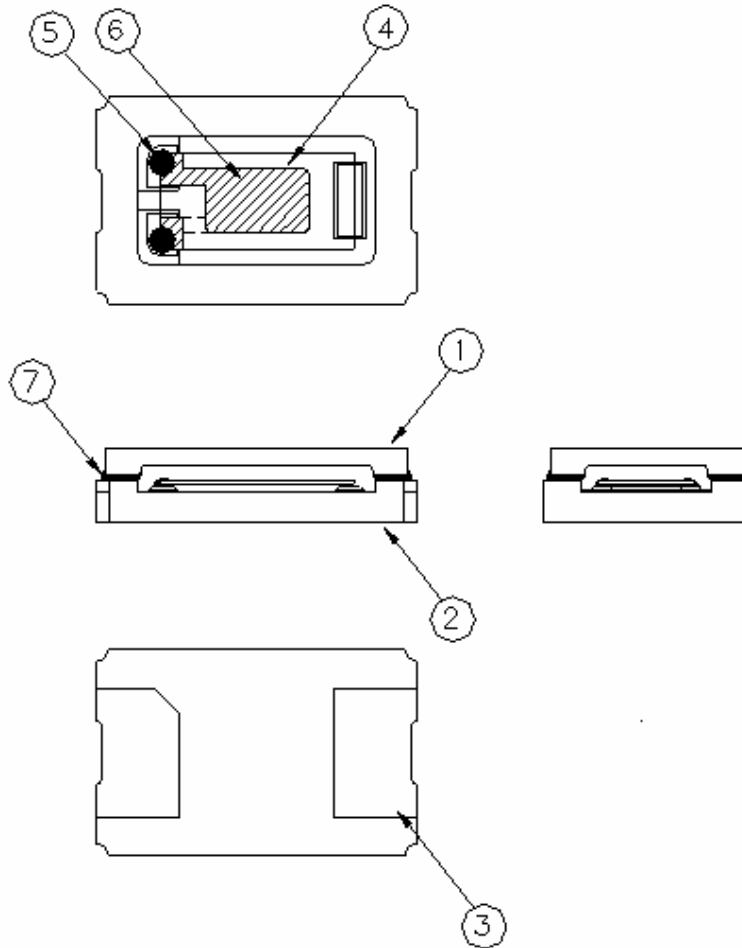

NO	COMPONENTS	MATERIALS	FINISH/SPECIFICATIONS
1	Cap	Ceramic	-
2	Base(Package)	Ceramic (Al ₂ O ₃)	Color black
3	PAD	Au	Tungsten metalize + Ni plating + Au plating
4	Crystal blank	SiO ₂	-
5	Conductive adhesive	Ag	Silicon resin
6	Electrode	Noble metal	-
7	Glass	-	-

PACKING : (EIA-481-2)

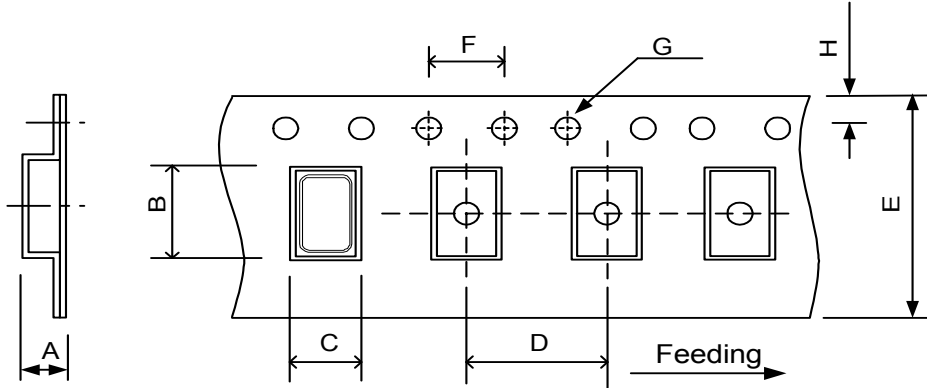

DIMENSIONS	A	B	C	D	E	F	G	H	
	1.40	5.40	3.60	8.00	12.00	4.00	1.55	1.75	(UNIT : mm)

REMARK :

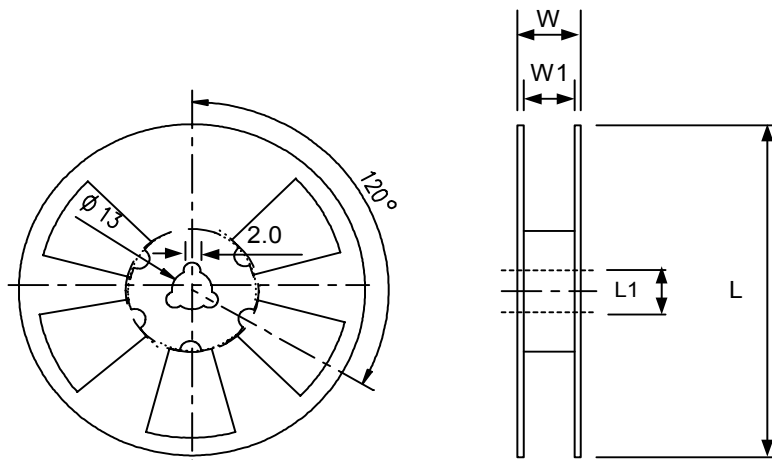
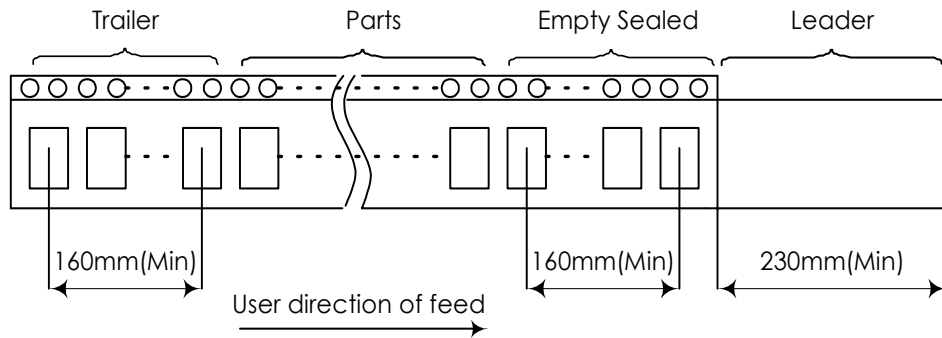

DIMENSIONS	L	L1	W	W1	pcs / Reel (UNIT : mm)
	180	13	16.5	12	Standard Reel Quantity is 1,000 pcs per reel

RELIABILITY SPECIFICATIONS
1.Mechanical Endurance

No.	Test Item	Test Methods	REF.DOC
1.1	Drop Test	75 cm height, fall freely onto concrete floor 3 times.	JIS C6701
1.2	Mechanical Shock	Device are shocked to half sine wave (1000 G) three mutually perpendicular axes each 3 times. 0.5m sec. duration time	MIL-STD-202F
1.3	Vibration	Frequency range 10 ~ 2000 Hz Amplitude 1.52 mm/20G Sweep time 20 minute Perpendicular axes each test time 4 hours (Total test time 12 hours)	MIL-STD-883E
1.4	Gross Leak	Standard Sample For Automatic Gross Leak Detector, Test Pressure: 2Kg / cm ²	MIL-STD-883E
1.5	Fine Leak	Helium Bombing 4.5 Kgf / cm ² for 2 hr	
1.6	Solderability	Temperature 260 ± 5 Immersing depth 0.5 mm minimum Immersion time 5 ± 1 seconds Flux Rosin resin methyl alcohol solvent (1 : 4)	MIL-STD-883E

2.Environmental Endurance

No.	Test Item	Test Methods	REF. DOC
2.1	Resistance To Soldering Heat	Pre-heat temperature 125 Pre-heat time 60 ~ 120 sec. Test temperature 260 ± 5 Test time 10 ± 1 sec.	MIL-STD-202F
2.2	High Temp. Storage	+ 125 ± 3 for 1000 ± 12 hours	MIL-STD-883E
2.3	Low Temp. Storage	- 40 ± 3 for 1000 ± 12 hours	
2.4	Thermal Shock	Total 100 cycles of the following temperature cycle 	MIL-STD-883E
2.5	High Temp & Humidity	85 ± 3 , RH 85% , 1000Hrs	JIS C5023
2.6	Pressure Cooker Storage	121 ± 3 , RH100% , 2 bar , 240Hrs	JIS C6701