

1. Device Name TCXO
2. Model Name DSB211SDN
3. Nominal Frequency 32.000 MHz
4. Mass 0.015g max.
5. Absolute Maximum Ratings

	Item	Symbol	Rating	unit
1	Supply Voltage	V <sub>CC</sub>	-0.3~+4.6	V
2	Storage Temperature Range	T <sub>STG</sub>	-40~+85	°C

## 6. Recommended Operating Conditions

	Item	Symbol	min.	typ.	max.	unit
1	Supply Voltage	V <sub>CC</sub>	+3.135	+3.3	+3.465	V
2	Load Impedance (resistance part) (parallel capacitance)	L <sub>LOAD_R</sub>	9	10	11	kΩ
		L <sub>LOAD_C</sub>	9	10	11	pF
3	Operating Temperature Range	T <sub>OPR</sub>	-30	-	+85	°C

## 7. Electrical Characteristics

(T<sub>A</sub>=-30~+85°C, L<sub>LOAD\_R</sub>/C=10kΩ//10pF, V<sub>CC</sub>=+3.3V, unless otherwise noted)

	Item	Conditions	Limits			unit	Notes
			min.	typ.	max.		
1	Current Consumption		-	-	+2.0	mA	
2	Output Level		0.8	-	-	V <sub>P-P</sub>	1
3	Symmetry	GND level (DC cut)	40/60	-	60/40	%	
4	Harmonics		-	-	-5	dBc	
5	Frequency Stability						
	1.Tolerance	After 2 times reflow Ref. to nominal frequency	-	-	±1.5	ppm	2,3
	2.vs Temperature	T <sub>A</sub> =-30~+85°C Ref. to frequency (T <sub>A</sub> =+25°C)	-	-	±0.5	ppm	
	3.vs Supply Voltage	V <sub>CC</sub> =+3.3V±5%	-	-	±0.2	ppm	
	4.vs Load Variation	L <sub>LOAD_R</sub> /C=(10kΩ//10pF)±10%	-	-	±0.2	ppm	
	5.vs Aging	T <sub>A</sub> =Room ambient	-	-	±1.0	ppm/year	
6	Start Up Time	@90% of final V <sub>out</sub> level	-	-	2.0	ms	
7	SSB Phase Noise	Relative to F0 level offset 1kHz	-	-	-125	dBc/Hz	

## Notes

1. Clipped sine wave (DC-coupled)
2. T<sub>A</sub>=+25°C
3. Please leave after reflow in 2h or more at room ambient.

TITLE  
DSB211SDN TYPE SPECIFICATION

Remark

Date  
2015/04/01

Spec. No.

Rev.  
-

Page  
1/2

### 8. Outline, Pin Connections

#### Outline

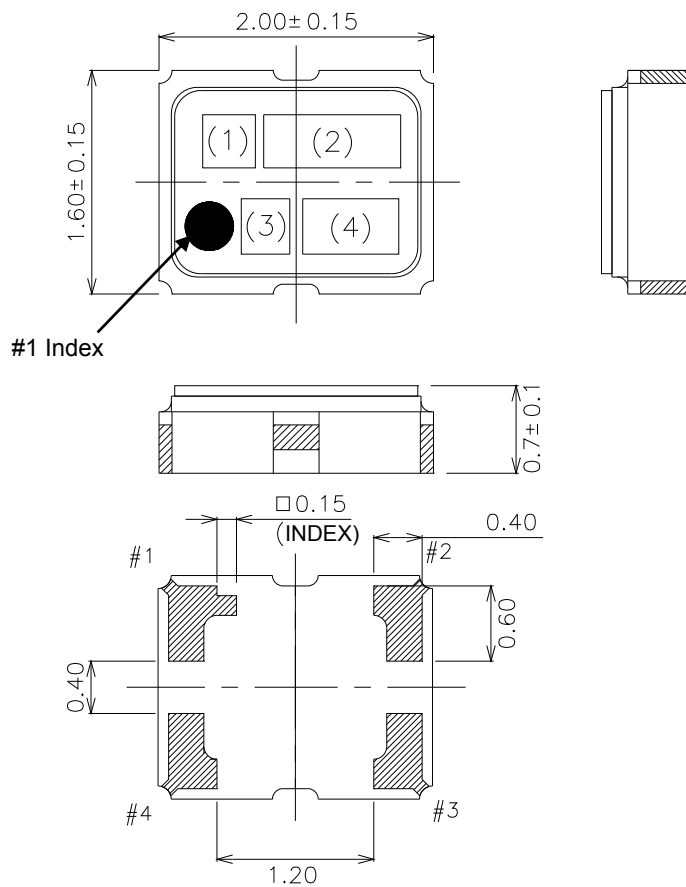

#### Pin Connections

Pin No.	Connection
#1	GND
#2	GND
#3	Output
#4	V <sub>cc</sub>

#### Marking

(1) Model code	BN
(2) Frequency	32.0 (MHz, 3digits)
(3) Logo	D
(4) Date code	Year (1digit) +Week (2digits) e.g.2015/1/1 → 501

unit: mm

Dimensional Tolerance: ±0.1

(Unless otherwise noted)

### 9. Measurement Circuit

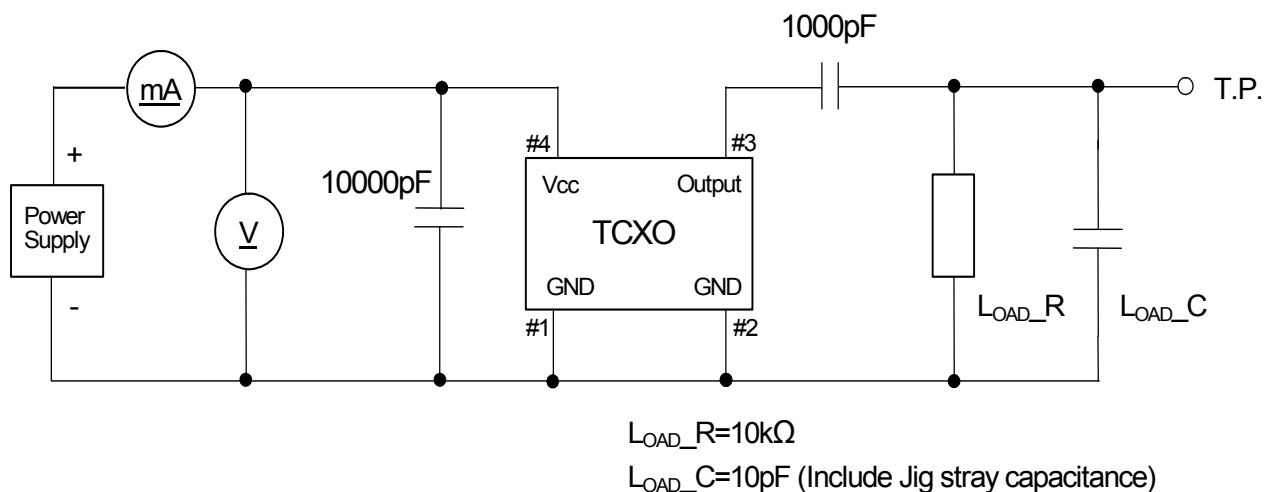

TITLE  
DSB211SDN TYPE SPECIFICATION

Remark

Date  
2015/04/01

Spec. No.

Rev.  
-

Page  
2/2